

Design No. X790
 Ratings — 1, 1-1/2, 2, 3 and 4 Hr.

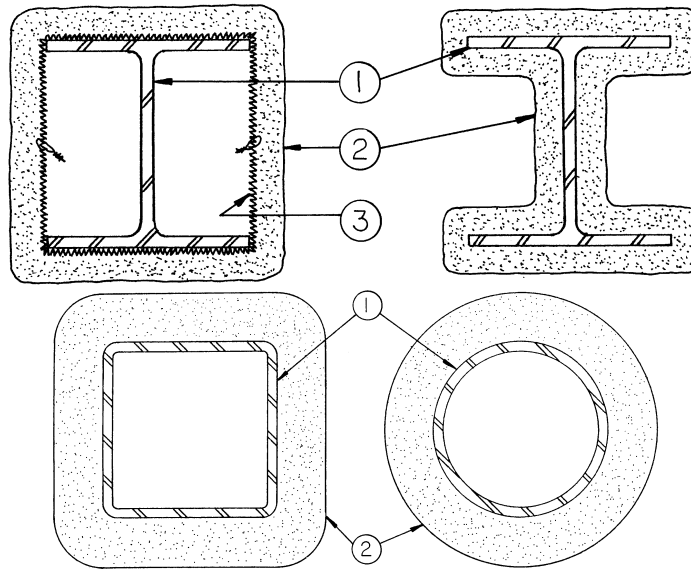

- Steel Column, Steel Pipe or Steel Tube** — Wide flange steel column (W) or steel circular pipe (SP) or steel square or rectangular tube (ST), min sizes as shown in the tables below.
- Spray-Applied Fire Resistive Materials*** — Applied by mixing with water and spraying in one or more coats to the thicknesses shown below, to steel surfaces which are clean and free of dirt, loose scale, and oil. Min average and min individual density of 15 and 14 pcf, respectively. For method of density determination, see Design Information Section, Sprayed Material.
 The min thickness of Spray-Applied Fire Resistive Materials required for various fire resistance ratings of contour sprayed or boxed wide flange columns are shown in the table below:

Column Size	W/D	1 Hr	1-1/2 Hr	Min Thkns In. 2 Hr	3 Hr	4 Hr
W6x9	0.33	15/16	1-1/4	1-9/16	2-1/8	2-11/16
W6x12	0.43	13/16	1-1/8	1-7/16	2	2-9/16
W6x16	0.57	11/16	1	1-5/16	1-7/8	2-3/8
W8x28	0.68	5/8	15/16	1-1/4	1-13/16	2-5/16
W10x49	0.83	9/16	13/16	1-1/8	1-5/8	2-1/8
W12x106	1.46	3/8	9/16	13/16	1-1/4	1-11/16
W14x233	2.52	1/4	3/8	1/2	7/8	1-3/16
W14x730	6.68	1/4	1/4	1/4	3/8	1/2

As an alternate to the above table, the required thickness of Spray-Applied Fire Resistive Materials to be applied to all surfaces of the steel columns for all rating periods may be determined from the following equations:

$$h = \frac{R}{75 (W/D) + 32}$$

(for column W/D range of 0.33 to 2.51)

$$h = \frac{R}{75 (W/D) + 15}$$

(for column W/D range of 2.51 to 6.68)

Where:

h = Spray-Applied Fire Resistive Materials thickness in the range of 1/4 to 4-1/2 in. (rounded up to the nearest 1/16 in.)

R = Fire resistance rating period in minutes (60-240 mins.)

D = Heated perimeter of the steel column in inches.

W = Weight of the steel column in lbs per foot.

The thicknesses contained in the table below are applicable when the Spray-Applied Fire Resistive Materials applied to the column's flange tips are reduced to one-half that shown in the table below (for contour application):

Column Size In.	1 Hr	1-1/2 Hr	Min Thkns In. 2 Hr	3 Hr	4 Hr
W6x9	1	1-3/8	1-3/4	2-7/16	3-1/8
W6x12	7/8	1-1/4	1-5/8	2-5/16	3-1/16
W6x16	3/4	1-1/8	1-7/16	2-1/16	2-11/16
W8x28	11/16	1	1-5/16	1-15/16	2-1/2
W10x49	5/8	15/16	1-3/16	1-3/4	2-3/8
W12x106	3/8	5/8	7/8	1-3/8	1-13/16
W14x233	5/16	3/8	9/16	15/16	1-5/16
W14x730	5/16	5/16	5/16	7/16	5/8

The min thickness of Spray-Applied Fire Resistive Materials required for various fire resistance ratings of contour sprayed steel pipes or tubes are shown on the table below:

Min Column Size In.	A/P	1 Hr	1-1/2 Hr	Min Thkns In. 2 Hr	3 Hr	4 Hr
SP 4x0.237	0.22	11/16	1	1-3/8	2-1/16	2-3/4
ST 4x4x0.1875	0.18	3/4	1-1/16	1-7/16	2-1/16	2-11/16
ST 4x4x0.3125	0.29	1/2	13/16	1-1/8	1-3/4	2-5/16

2013 FIRE RESISTANCE DIRECTORY - ISOLATEK

320

FIRE-RESISTANCE RATINGS - ANSI/UL 263 (BXUV)

Min Column Size In.	A/P	1 Hr	1-1/2 Hr	Min Thkns In. 2 Hr	3 Hr	4 Hr
ST 4x4x0.375	0.34	7/16	3/4	1	1-9/16	2-1/8
ST 4x4x0.5	0.44	3/8	9/16	7/8	1-3/8	1-7/8
ST 36x24x0.5	0.49	5/16	7/16	11/16	1-1/8	1-9/16

As an alternate to the table above, the required thickness of Spray-Applied Fire Resistive Materials to be applied to all surfaces of the steel pipes or tubes for all rating periods may be determined from the following equation:

$$h = \frac{R}{188 (A/P) + 45}$$

Where:

h = Spray-Applied Fire Resistive Materials thickness in the range of 5/16 to 4-1/4 in. (rounded up to the nearest 1/16 in.)

R = Fire resistance rating in minutes (60-240 mins.)

A = Cross-sectional area of pipe or tube.

P = Heated perimeter of steel pipe or tube.

A/P = 0.18 to 0.49.

The A/P ratio of a circular pipe is determined by:

$$A/P = \frac{t (d - t)}{d}$$

Where:

d = the outer diameter of the pipe (in.)

t = the wall thickness of the pipe (in.)

The A/P ratio of a rectangular tube is determined by:

$$A/P = \frac{t (a + b - 2t)}{a + b}$$

Where:

a = the outer width of the tube (in.)

b = the outer length of the tube (in.)

t = the wall thickness of the tube (in.)

BERLIN CO LTD — Types 300, 300ES, 300N or SB.

ISOLATEK INTERNATIONAL — Type 300, 300AC, 300ES, 300HS, 300N or SB.

LUCKY CORE INSULATING MATERIALS

MANUFACTURING L L C — Types 300, 300ES, 300N, or SB.

NEWKEM PRODUCTS CORP — Types 300, 300ES, 300N or SB.

- 2A. (As an alternate to Item 2) **Spray-Applied Fire Resistive Materials*** — Applied by mixing with water and spraying in one or more coats to the thicknesses shown below, to steel surfaces which are clean and free of dirt, loose scale, and oil. Min average and min individual density of 17.5 and 16 pcf, respectively, for Type 300TW. Min average and min individual density of 22 and 19 pcf, respectively, for Type 400. For method of density determination, see Design Information Section, Sprayed Material.

The min thickness of Spray-Applied Fire Resistive Materials required for various fire resistance ratings is shown in Item 2.

BERLIN CO LTD — Type 400.

ISOLATEK INTERNATIONAL — Type 300TW or Type 400

LUCKY CORE INSULATING MATERIALS

MANUFACTURING L L C — Type 400.

NEWKEM PRODUCTS CORP — Type 400.

- 2B. (As an alternate to Item 2 and 2A) — **Spray-Applied Fire Resistive Materials*** — Prepared by mixing with water according to instructions on each bag of mixture and spray- or trowel-applied to steel surfaces which are free of dirt, oil or scale. Min average density of 17.5 pcf with min individual value of 17.0 pcf. For method of density determination, see Design Information Section, Sprayed Material.

The min thickness of Spray-Applied Fire Resistive Materials required for various fire resistance ratings is shown in Item 2.

ISOLATEK INTERNATIONAL — Type 280.

3. **Metal Lath** — (Optional for contour application) — 3.4 lb/sq yd galv or painted expanded steel lath. Lath shall be lapped 1 in. and tied together with No. 18 SWG galv steel wire spaced vertically 6 in. OC.

*Bearing the UL Classification Mark